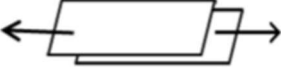

Adhesive Hook & Loop Grade 102

Technical Information:

Adhesive/Hook	Adhesive/Loop
Base Material: Nylon/Polyester	Base Material: Nylon/Polyester
Construction: Surface Yarn – Nylon and Ground Yarn – Polyester	Construction: Surface Yarn – Nylon and Ground Yarn – Polyester
Adhesive: Synthetic rubber resin	Adhesive: Synthetic rubber resin
Paper liner: 80 gsm	Paper liner: 80 gsm
Width Tolerance: +/- 5%	Width Tolerance: +/- 5%
Temperature resistance, softening point: 180°C	Temperature resistance, softening point: 180°C
Fusing point: 215°C	Fusing point: 215°C
Adhesive colour: Light Yellow	Adhesive colour: Light Yellow
Standard Width Available: 16mm, 20mm,25mm,30mm, 38mm,50mm,100mm,	Standard Width Available: 16mm, 20mm,25mm,30mm, 38mm,50mm,100mm,
Standard Length: 25 metres	Standard Length: 25 metres
Temperature resistance adhesive: ASTM E28-67	
Melting Point: 85 +/- 2°C	
Humidity: 50% Hook & Loop strength in water, can be completely recovered after drying.	
Application Temperature: +5°C to +30°C	
Service temperature: -20°C to +60°C	
Typical Application and Performance: Immediate adhesion to a variety of surfaces including paper, wood, polythene, metal, glass, plastic etc. A strong instant bond. It is recommended to avoid application of the product on surfaces of humidity, dust or oil.	

Radamex Brzozowa 1; 05-822 Milanówek; rzepy@rzepy.net; www.rzepy.net

Peel Strength ASTM D5170 / EN 12242	Average:
	
After 1 opening & closing cycle	1.3 N/cm
Shear Strength ASTM D5169 / EN 13780	Average:
	
After 1 opening & closing cycle	12 N/cm ²
Peel Strength 180° ASTM D3330	Average:
180 ° Peel Strength FTM1	14 N/cm

Radamex Brzozowa 1; 05-822 Milanówek; rzepy@rzepy.net; www.rzepy.net

Adhesive Hook & Loop Grade 101

Issue Date: 25th Nov 2020

Version:1

Issued by: K. Astley

Technical Information:

Adhesive/Hook	Adhesive/Loop
Base Material: Nylon/Polyester	Base Material: Nylon/Polyester
Construction: Surface Yarn – Nylon and Ground Yarn - Polyester	Construction: Surface Yarn – Nylon and Ground Yarn - Polyester
Adhesive: Synthetic rubber resin	Adhesive: Synthetic rubber resin
Paper liner: 140 gsm	Paper liner: 140 gsm
Width Tolerance: +/- 5%	Width Tolerance: +/- 5%
Temperature resistance, softening point: 180°C	Temperature resistance, softening point: 180°C
Fusing point: 215°C	Fusing point: 215°C
Adhesive colour: Light Yellow	Adhesive colour: Light Yellow
Standard Width Available: 16mm, 20mm,25mm,30mm, 38mm,50mm,100mm, 150mm	Standard Width Available: 16mm, 20mm,25mm,30mm, 38mm,50mm,100mm, 150mm
Standard Length: 25 metres	Standard Length: 25 metres
Typical Application and Performance: Immediate adhesion to a variety of surfaces including paper, wood, polythene, metal, glass, plastic etc. A strong instant bond. It is recommended to avoid application of the product on surfaces of humidity, dust or oil.	

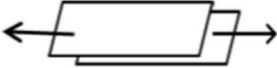
Peel Strength ASTM D5170 / EN 12242	Average:
	
After 1 opening & closing cycle	1.4 N/cm
Shear Strength ASTM D5169 / EN 13780	Average:
	
After 1 opening & closing cycle	14 N/cm ²

Radamex Brzozowa 1; 05-822 Milanówek; rzepy@rzepy.net; www.rzepy.net



Radamex Brzozowa 1; 05-822 Milanówek; rzepy@rzepy.net; www.rzepy.net

Issue Date: 25th Nov 2020

Version:1

Issued by: K. Astley

Peel Strength 180° ASTM D3330	Average:
180 ° Peel Strength FTM1	17.9N/cm
90 ° Peel Strength FTM2	15.7N/cm
Shear Strength FTM8	60 hrs/kg

Radamex Brzozowa 1; 05-822 Milanówek; rzepy@rzepy.net; www.rzepy.net



Certificate Number 8158
ISO 9001:2015